

Company: Joyoung International Trading Co., Limited

Atten: Smiling

Mobile/WhatsApp/Wechat: +86 18050035902

Email: info@htechplc.com

Website: <https://www.joyoungintl.com/>



INSTALLATION and OPERATING MANUAL

Digital Energy™ STS-230-25/40/63-2-RM

Rack-mount Static Transfer Switch
230V-25/40/63A-2-pole

GE Digital Energy™
General Electric Company
CH - 6595 Riazzino (Locarno)
Switzerland

Telephone +41 (0)91 / 850 51 51
Fax +41 (0)91 / 850 51 44
Website www.gedigitalenergy.com





INSTALLATION AND OPERATING MANUAL
Digital Energy STS-230-25/40/63 Static Transfer Switch
LX-DOC File: OPM_STS_230_25A_2RM_1GB_V012
Manual version 1.2 June 2004



INSTALLATION and OPERATING MANUAL

Digital Energy™ STS-230-25/40/63-2-RM Rack-mount Static Transfer Switch 230V-25/40/63A-2-pole

Preface

We thank you for selecting a **General Electric Digital Energy™ STS Series Static Transfer Switch** and recommend that you read these instructions carefully before installation and start-up of the device.

The instructions in this manual are for:

1-phase 2-pole rack-mount models STS-230-25-2-RM, STS-230-40-2-RM and STS-230-63-2-RM

Please keep this manual in a safe place for future reference and carefully read the important safety instructions in chapter 1 before installation of this device.

© 2004 by **GE Consumer & Industrial**

All rights reserved.

The information contained in this publication is intended solely for the purposes indicated.

The present publication and any other documentation supplied with the Static Transfer Switch system is not to be reproduced, either in part or in its entirety, without the prior written consent of GE.

The illustrations and plans describing the equipment are intended as general reference only and are not necessarily complete in every detail.

The content of this publication may be subject to modification without prior notice.



CONTENTS

1 IMPORTANT SAFETY INSTRUCTIONS3

 1.1 Save these instructions

 1.2 Safety warnings and symbols

 1.3 General

 1.4 Intended use

 1.5 Transport, storage, unpacking

 1.6 Installation

 1.7 Electrical connection

 1.8 Operation

 1.9 Fire regulations

 1.10 Standards applied and conformity

2 INTRODUCTION8

 2.1 Warranty

 2.2 Description

 2.3 Application

3 INSTALLATION12

 3.1 Transport

 3.2 Unpacking

 3.3 Location

 3.4 Installation

 3.5 Connection

 3.5.1 Connection with optional Switch Board

 3.5.2 Connection without Switch Board

 3.6 Starting up

 3.6.1 Starting up with Switch Board

 3.6.2 Starting up without Switch Board

4 OPERATION17

 4.1 Operation mode settings

 4.1.1 Preferred source selection

 4.1.2 Automatic retransferring

 4.1.3 Manual operation

 4.1.4 Reset button

 4.2 Manual bypass operation with Switch Board

 4.2.1 Bypassing load to primary source

 4.2.2 Return from primary bypass mode to STS operation

 4.2.3 Bypassing load to secondary source

 4.2.4 Return from secondary bypass mode to STS operation

 4.3 Service

 4.3.1 STS operation test

 4.3.2 Trouble shooting

 4.3.3 Service exchange of SCR Board with primary bypass

 4.3.4 Service exchange of SCR Board with secondary bypass

 4.4 Parameter settings (dip switches)

 4.5 Default dip switch settings

 4.6 Terminals

 4.6.1 Relay communication terminal block

 4.6.2 High current terminal

 4.7 Fuse selection

5 SPECIFICATIONS30

 5.1 Technical data

 5.2 Dimensions



1 - Important Safety Instructions

1.1 Save these instructions

This manual contains important instructions that should be followed during erection, installation, use and maintenance of the Static Transfer Switch. Before attempting to erect, install and use of the device, carefully read this manual. Keep this manual next to the device for future references

Full understanding of and compliance with the safety instructions and warnings contained in this manual are
THE ONLY CONDITION
 to avoid any dangerous situation during erection, installation, operation and maintenance work, and to preserve the maximum reliability of the system.

In the event of equipment failures or special problems it is not permitted to take unauthorised remedial action. In such cases the responsible GE technical service department must be contacted and the required information obtained.

GE refuses any responsibility in case of non-observance, unauthorized alterations or improper use of the delivered device.

While every care has been taken to ensure the completeness and accuracy of this manual, GE accepts no responsibility or liability for any loss or damage resulting from the use of the information contained in this document

This document shall not be copied nor reproduced without the permission of GE.

Due to technical improvements, some of the information contained in this manual may be changed without notice

1.2 Safety warnings and symbols

Safety warnings

The text of this manual contains warnings to avoid risk to persons and to avoid damages to the UPS system and the supplied critical loads. Do not proceed beyond these warnings if you do not fully understand and/or are not able to meet the mentioned conditions.

The non-observance of the warnings reminding hazardous situations could result in human injury and equipment damage. Please pay attention to the meaning of the following warnings and symbols.

	<p>WARNING !</p> <p>Refers to procedures or operations which, when not correctly performed, could cause personal injury or serious damage to the system</p>
---	--

	<p>NOTE</p> <p>Warns the user about important operations or procedures described in this manual</p>
---	--



Safety Symbols

	<p>CAUTION</p> <p>The product may be in danger: when procedures or operations are not correctly performed, damage to the product may be the result.</p>
---	--

	<p>DANGER OF PARTS ELECTRICALLY LIVE</p> <p>Related to all situations with potentially hazardous voltage</p>
---	---



1.3 General

	<p>DANGER! RISK OF ELECTRIC SHOCK.</p> <p>When the STS operates, some of its parts are necessarily under a hazardous voltage.</p> <p>Do not remove the cover; there are no user serviceable parts inside.</p> <p>There may be danger, loss of life or personal injury if warnings are not strictly observed.</p>
	<p>CAUTION</p> <p>There may be damage to the equipment if procedures and practices are not strictly observed and followed.</p>
	<p>NOTE</p> <p>Do not attempt to service the STS unless you have had proper training. Refer all maintenance and servicing to properly qualified, skilled and competent service personnel.</p>

Properly qualified, skilled and competent service personnel are persons who:

- Are familiar with the erection, installation and operation of the equipment and the system that is being installed.
- Are capable of performing switching operations according to safety technology standards and entitled and authorized to switch the equipment on and off and to isolate from the voltage.
- Are instructed according to the standards of safety technology in the care and use of safety equipment.
- Are trained to immediate rescue measures (first aid).
- Have completed instructions with appropriate confirmation of GE.

1.4 Intended use

- A Static Transfer Switch (STS) is designed to transfer power supply between independent AC power sources, thus protecting the connected load from power supply interruptions. It protects automatic systems for power industry, power supply systems for petrochemical industry, computer and telecommunication centers, automatic and security systems of 'intelligent' buildings as well as other equipment that is highly sensitive for power supply interruptions.
- The STS is intended to be operated by technically qualified personnel.
Technically qualified personnel are persons who (because of their training, experience, and position as well as their knowledge of appropriate standards, regulations, health and safety requirements and working conditions) are authorised to be responsible for the safety of the equipment, at all times whilst carrying out their normal duties and are therefore aware of, and can report, possible hazards (observe IEC 364, DIN VDE 0105 and national wiring regulations and accident prevention rules).
- The technical data as well as information concerning connecting requirements can be found on the rating label and in this document and shall be strictly observed.



1.5 Transport, storage, unpacking

- The STS should be transported in a container truck with shock protection against moves during transport. The STS should be belted to the wall of the container.
- Any special treatment during storage of the STS is not needed.
- Move the STS in its original package to the final destination room.
- Check for sufficient floor and elevator loading capacity.
- Immediately after unpacking carefully check the integrity of the equipment. In case you note recognizable damage, do not connect any voltage to the STS, do not put the STS into operation, but contact the nearest Service Centre.

1.6 Installation

The following instructions are provided for the personal safety of operators and also for the protection of the described product and connected equipment.

- Observe the prescribed accident prevention and safety rules for the specific application.
- When installing the STS strictly observe all information on technical data and operating conditions. Comply with all warnings, and strictly follow the procedures and practices as described in this manual.
- This STS is intended to be used in a controlled indoor environment and free of conductive contaminants and protected against animal intrusion.
- Check for sufficient floor loading capacity.
- Avoid placing the unit in direct sunlight or near heat sources.
- It is important that the unit has adequate ventilation. Maintain air movement around and through the unit. Do not block the air vents.
- The unit must be placed in a sufficiently ventilated area; the ambient temperature should not exceed 40°C (104°F).
- Do not install the STS in an excessively humid environment or near water.
- Avoid spilling liquids or dropping any foreign object into the STS.
- Emergency stop devices must be provided for all applications. An emergency stop must inhibit any further uncontrolled operation.
- The electric connections must be covered.
- Earth connection must be checked for safe function after assembly.
- Countermeasures should be taken to avoid accidental turning on of previously switched off systems through either a control vault or a third party (e.g. key switches).
- Do not touch electronic components. They may be electrostatic sensitive and are for that reason easily damaged due to improper handling.
- To avoid potential health risks, electrical components should not be mechanically damaged or destroyed.
- Isolate from mains and battery before installation or dismantling work, as well as for fuse changes or post installation modifications.



1.7 Electrical connection

- All electrical connections are to be realized by properly qualified, skilled and competent service personnel only.
- When working on live STS, be sure to comply with the applicable national accident prevention rules.
- Before putting into operation make sure that the rated voltage for the unit conforms with the local supply voltage.

1.8 Operation

- These instructions cover normal operation in the automatic as well as in manual modes. Special operating conditions, such as short circuit tests, input supplies, etc., are not covered in this document. These operating modes require comprehensive knowledge of the overall system and should be carried out by properly qualified, skilled and competent service personnel only.
- Operators shall make sure that the system is ready for operation and that all cabinet doors are properly closed before switching it on.
- Warning signs are placed on all cabinet doors to warn of excessive voltage (over 50 V) in the control cabinets, but also of voltages in the power section and enormous short circuit currents. These signs supply a warning not to open the doors during operation.



DANGER ! High Voltage!

Only qualified personnel may carry out work or manipulation of the device.

- Operators are prohibited from performing any work inside the control cabinets.
- Service and maintenance will not be covered in this document.

1.9 Fire regulations



WARNING

Should a fire break out inside the system, a fire extinguisher with CO₂ or halogen must be used. Do not inhale vapors.



1.10 Standards applied and conformity

European Standards	
Standard	Description
EN 60950	Safety of information technology equipment, including electrical business equipment
EN 50178 (project)	Equipment of Power Plants with electronic resources
IEC 600076	Power transformers
IEC 60146-1-2	General requirements and line commutated converters
IEC 60529	Degrees of protection provided by enclosures (IP codes)
IEC 60617	Graphical symbols and diagrams
EN 50082-2	EMC Requirements
DIN 41773 Part 1	Static power converters, semiconductor rectifiers equipment with IU characteristics for charging of Lead Acid batteries - guideline



The standards mentioned above fulfil the requirements for CE marking.

The product mentioned in this manual conforms to the relevant requirements to the appropriate EU Directive, i.e. that this product meets all relevant EU Directives and that it can be sold inside the European Union without national commercial hindrances.

Relevant EU Directives for GE are called EMC- and Low Voltage Directives:

- EU Directive on Electromagnetic Compatibility 89/336/EU, in version 92/31/EU, 93/68/EU
- EU Directive on Electrical Equipment designed for use within certain Voltage Limits (Low Voltage Directive) 73/23/EU, in version 93/68/EU

The directives themselves define only on a modest scale what's to do and refer to the harmonised Standards. One of the EU harmonised product standards is applicable for rectifier systems. According to this standard GE fulfils the basic requirements.



2 - Introduction

2.1 Warranty

GE Digital Energy, operating through its authorized agents, warrants that the standard products will be free of defects in materials and workmanship for a period of 24 months after the date of invoice, or such other period as may be specified.

	<p>NOTE This warranty does not cover failures of the product which result from incorrect installation, misuse, alterations by persons other than authorized agents, or abnormal operating conditions</p>
--	---

2.2 Description

Static Transfer Switches type STS-230-XX (STS-230-25, STS-230-40 and STS-230-63) are designed for switching between two alternative electrical power sources without supply interruption for energy receivers. The static transfer switch (STS) is connected to two sources of electrical power with terminals called X01 PRIMARY SOURCE and X02 SECONDARY SOURCE. The rated voltage of both sources is 230V AC and the frequency is 50Hz. Depending on the current settings and the state of the system, one of the two sources (PRIMARY SOURCE or SECONDARY SOURCE) is “connected” to the output terminal called X03 STS OUTPUT. Possible methods for transferring the load from one source to other one are explained in chapter 4.

Optionally the device is equipped with a Switch Board. The Switch Board consists of an Integrated Switch (K1, K2, K3, K4 and K5) and it functions as manual bypass that allows uninterruptible exchange of the STS. Mechanical arrangement of the Integrated Switch ensures “brake before make” type of switching and their proper sequence.

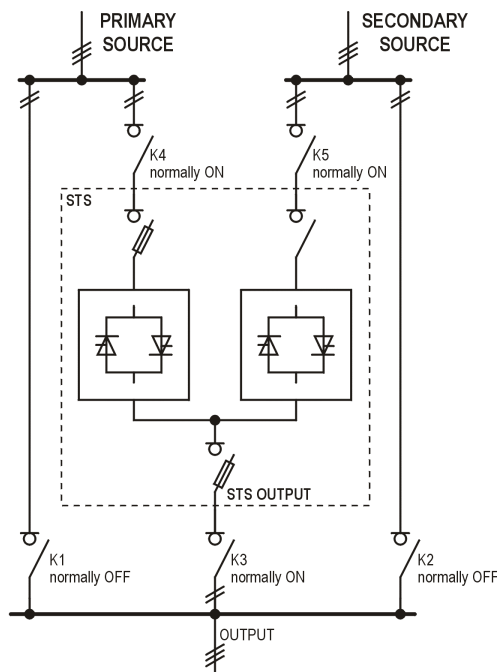

Figure 1. Electrical diagram of Static Transfer Switch (STS) with manual bypasses

Each single line on the diagram represents two wires inside the STS-230-XX. PRIMARY SOURCE, SECONDARY SOURCE and STS OUTPUT connections consist of three wires each including Protective Earth (PE).

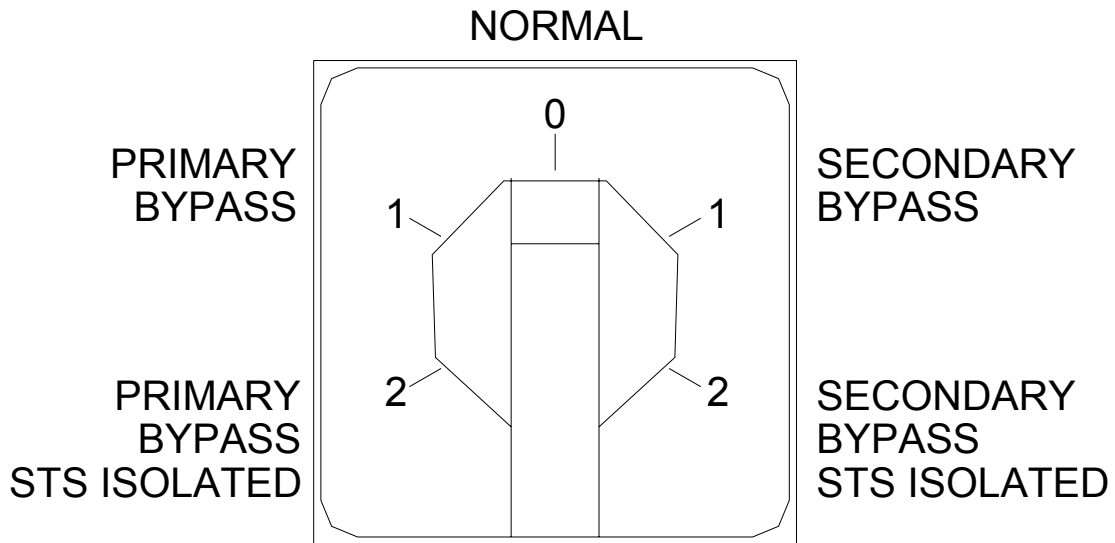

Figure 2. Positions of Integrated Switch

Depending on Integrated Switch position, each of the switches K1, K2, K3, K4 and K5 is either closed (“ON”) or opened (“OFF”) as in table 1.

Integrated switch position		Switch state				
	No	K1	K2	K3	K4	K5
		PRIMARY BYPASS	SECONDARY BYPASS	STS OUTPUT	PRIMARY SOURCE	SECONDARY SOURCE
NORMAL	0	OFF	OFF	ON	ON	ON
PRIMARY BYPASS	1	ON	OFF	ON	ON	OFF
PRIMARY BYPASS STS ISOLATED	2	ON	OFF	OFF	OFF	OFF
SECONDARY BYPASS	1	OFF	ON	ON	OFF	ON
SECONDARY BYPASS STS ISOLATED	2	OFF	ON	OFF	OFF	OFF

Table 1

In the normal mode of operation, the process of transferring the supply from one input to the other one is performed automatically. The start up procedure is described in chapter 3. Operation is explained in chapter 4.

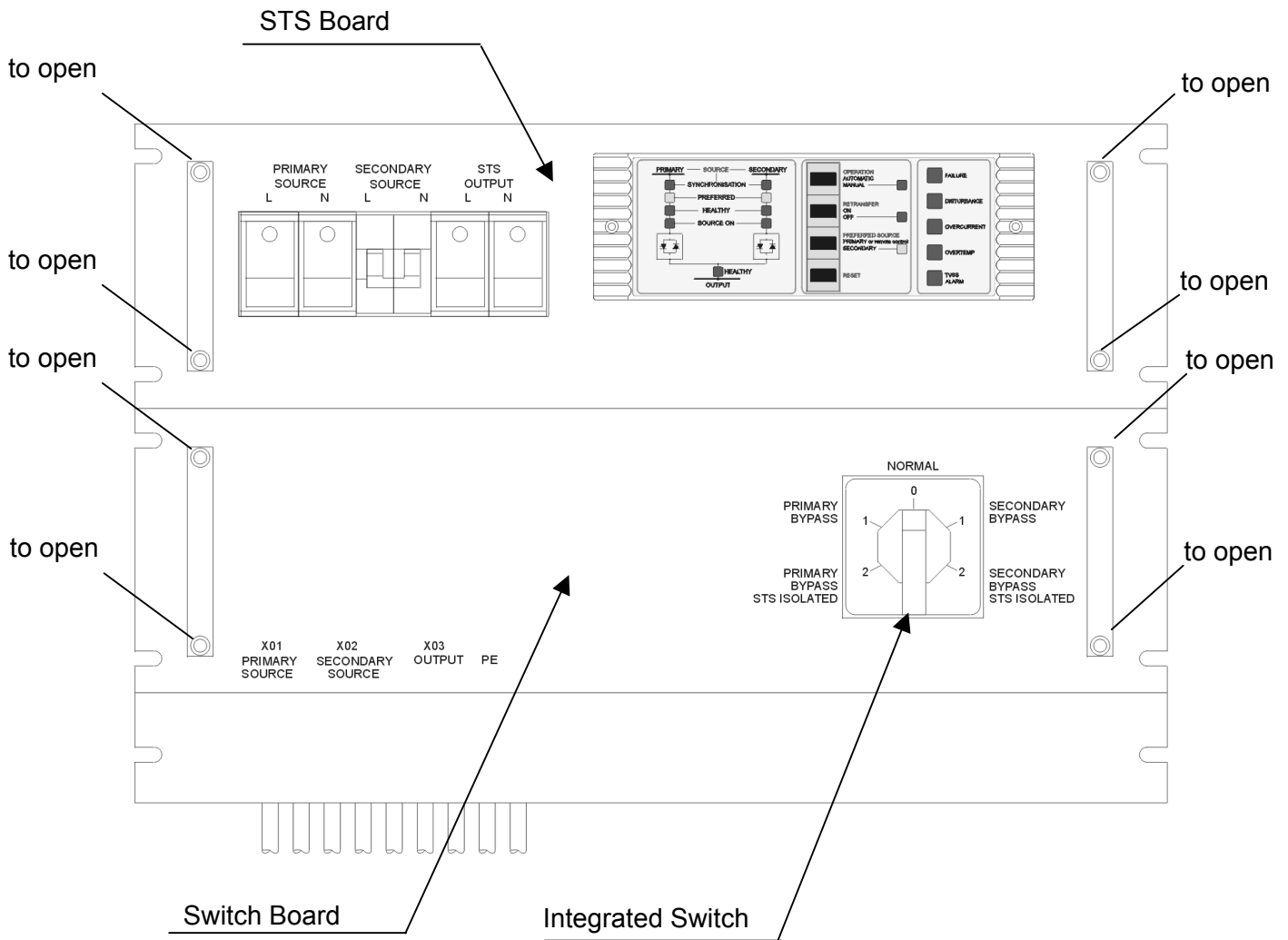

Figure 3. Front panel view

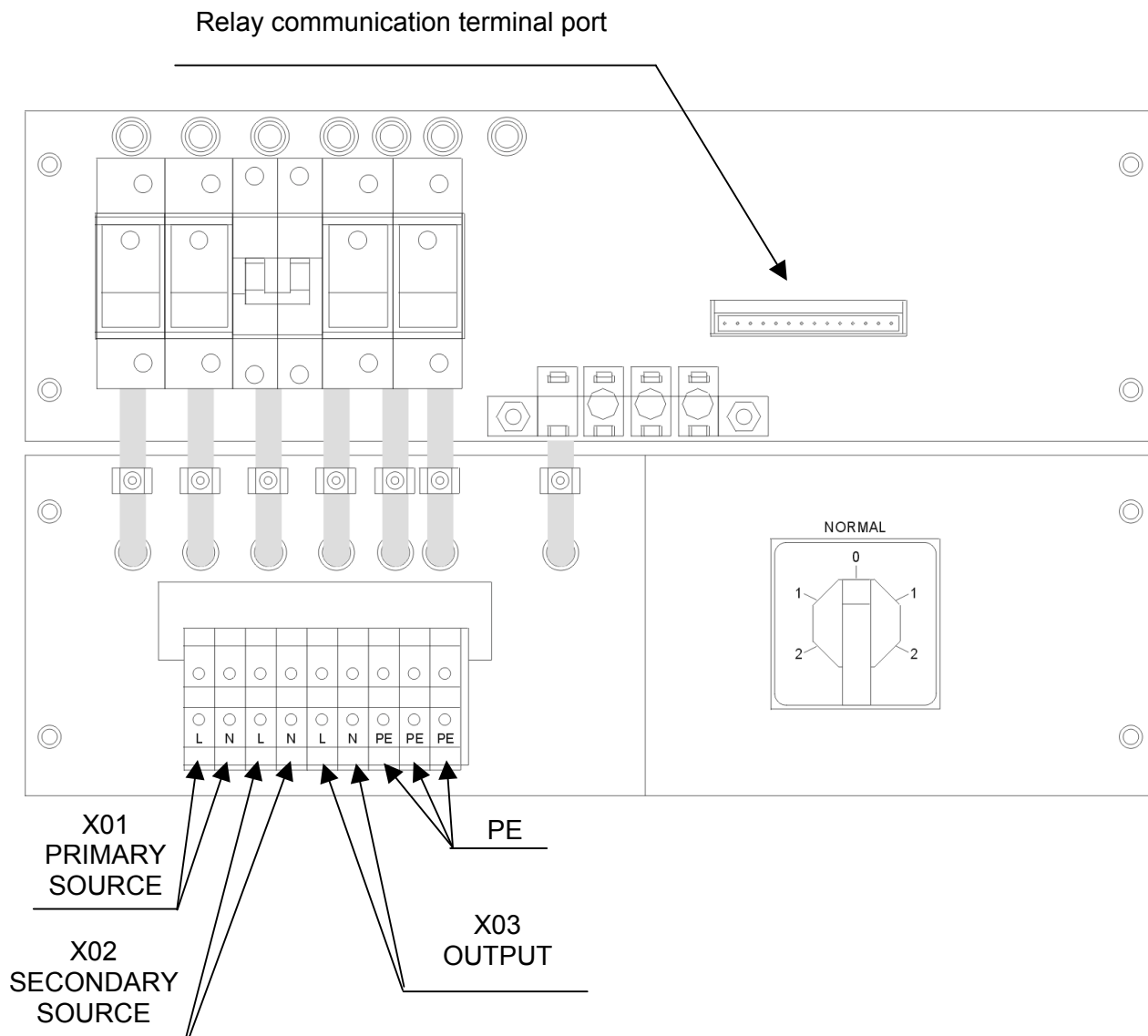

Figure 4. High current terminals (view without front covers)

2.3 Application



The STS-230-XX is designed to operate with two electrically separated electrical power sources connected to terminals X01 PRIMARY SOURCE and X02 SECONDARY SOURCE. The sources are connected to the STS with a three-wire cable each (one wire for phase, one for neutral and one for PE). Electrical parameters of the input sources (PRIMARY SOURCE and SECONDARY SOURCE) and output external circuit (STS OUTPUT) should meet specification for the STS. Three cables coming into the STS, two from sources and one from the load, create three outgoing lines on the diagram showed on figure 1. Lines going from the sources are called input lines and consequently the line going to the load is called output line. Input lines voltages and output line currents values should not exceed acceptable ranges.

3 - Installation

3.1 Transport

The STS should be transported in a container truck with shock protection against moves during transport. The STS should be belted to the wall of the container. Because of limitation of height for air transport up to 1.6 meter, the STS is placed horizontally on a palette.

Move the STS in its original package to the final destination room using a pallet truck or forklift.

	<p>CAUTION</p> <p>During transport, pay attention to:</p>	 <p>FRAGILE</p>	 <p>SENSITIVE TO DAMPNES</p>
---	--	--	---

For storage and transport the cabinet of the Static Transfer Switch (STS) is covered with cardboard sheet belted with steel wrapping bands to europalettes or other suitable for forklift transport.

The package box supplies the following information:

- Name or logo of manufacturer
- Quality control sign
- Warnings according to PN-67/O-79252 Standard

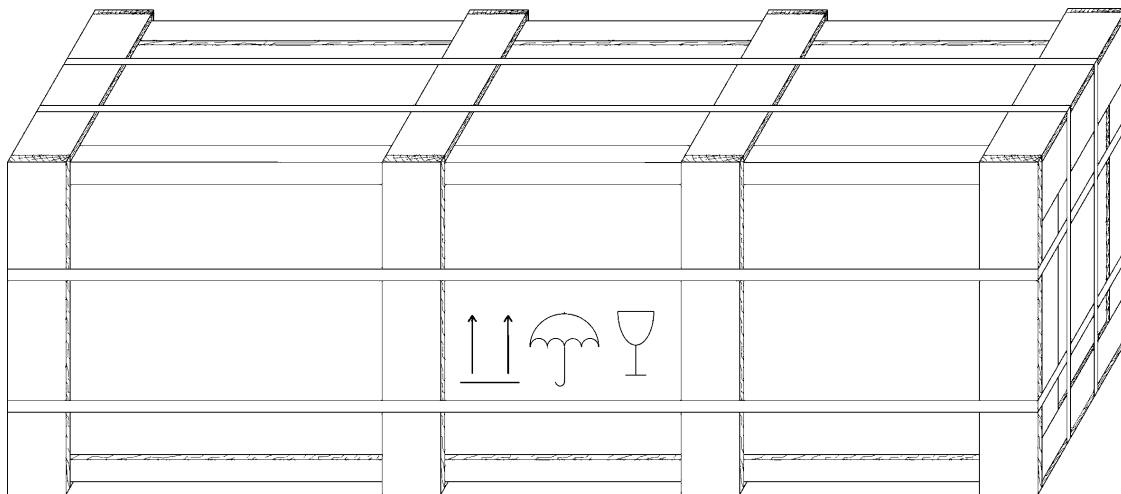

Figure 5. View of crate package

In case of installing a STS on upper levels, four lifting eyes are available on top of the cabinet allowing transport with a crane or others.

The STS should be stored in closed rooms free of chemically aggressive vapours, temperature 0°C to +40°C and humidity lower than 90% at 20°C.



3.2 Unpacking

1. Cut the wrapping bands, and remove the shipping box.
2. Immediately after unpacking carefully check the integrity of the equipment. In case you note recognizable damage,
 - notify the carrier and place of purchase
 - contact the nearest Service Center.



WARNING! In case of recognizable damage:

DO NOT connect any voltage to the unit
DO NOT put the unit into operation

3. Turn the unit into vertical position and place it on a frame. Screw the pedestal of the STS to the frame.
4. Recycle the packing material in compliance with all applicable regulations.

3.3 Location

- This STS is intended to be used in a controlled indoor environment and free of conductive contaminants and protected against animal intrusion.
- Check for sufficient floor loading capacity.
- Avoid placing the unit in direct sunlight or near heat sources.
- It is important that the unit has adequate ventilation. Maintain air movement around and through the unit. Do not block the air vents.
- The unit must be placed in a sufficiently ventilated area; the ambient temperature should not exceed 40°C (104°F).
- Do not install the STS in an excessively humid environment or near water.
- Avoid spilling liquids or dropping any foreign object into the STS.



3.4 Installation

	<p>NOTE</p> <p>The STS may only be installed by properly qualified, skilled and competent service personnel. Refer to section 1.3 for further details.</p>
---	---

	<p>CAUTION</p> <p>Make sure that condensation does not occur as a result of a relatively low temperature of the unit. Especially if transport took place at sub-zero temperatures, allow the unit to warm up before installation and starting up.</p>
---	--

Connections between boards in the STS-230-XX and external cable connections are being made during the installation procedure.

- When installing the STS strictly observe all information on technical data and operating conditions. Comply with all warnings, and strictly follow the procedures and practices as described in this manual.
- Do not touch electronic components. They may be electrostatic sensitive and are for that reason easily damaged due to improper handling.
- To avoid potential health risks, electrical components should not be mechanically damaged or destroyed.

	<p>NOTE</p> <p>Before making any connection and switching on the STS, check the following conditions.</p>
---	--

- Make sure that the rated voltage and frequency for the unit corresponds with the local supply voltage and frequency.

	<p>NOTE</p> <p>Rated voltage of both sources is 230V AC phase to neutral and the frequency is 50Hz.</p>
---	--

- Make sure that the total power requirement of the equipment connected to the STS does not exceed the rated output power of the STS.

	<p>CAUTION</p> <p>Wrong connection of the external sources to the STS-230-XX may cause a fault inside the STS-230-XX and unpredicted operation of external devices connected to the STS-230-XX.</p>
---	--



3.5 Connection

3.5.1 Connection with optional Switch Board

If the STS is equipped with the optional Switch Board, proceed as follows:

1. Switch off the supply in both supplying lines outside the STS-230-XX. Switches for both sources may be placed in some distance to the STS depending on the topology of the rest of the power system.
2. Check the absence of the voltage in the two input lines with a proper voltmeter.
3. Unscrew 4 screws from the Switch Board (figure 3), and take out the front cover plate.
4. Unscrew 4 screws from STS Board (figure 3), disconnect the Control Panel (ribbon cable inside STS Board) and take out the front cover plate.
5. Connect wires outgoing from the top part of the lower board into the proper terminals in the upper board (figure 5).
6. Turn the Integrated Switch placed on the Switch Board into position "0 NORMAL".
7. Firmly connect three wires coming from the first supplying device (PRIMARY SOURCE) into the X01 PRIMARY SOURCE terminal and one of the PE terminals placed on the Switch Board.
8. Firmly connect three wires coming from the second supplying device (SECONDARY SOURCE) into the X02 SECONDARY SOURCE terminal and one of the PE terminals placed on the Switch Board.
9. Firmly connect wires going to the load (OUTPUT) into the X03 OUTPUT terminal and one of the PE terminals placed on the Switch Board.
10. Check the connection of three external lines. Especially the output line going to the load should be connected to the proper terminal in the STS.
11. Reinstall the covers of both boards and fasten them with screws. Remember to connect the ribbon cable inside the STS Board.

3.5.2 Connection without Switch Board

If the STS is *not* equipped with the optional Switch Board, proceed as follows:

1. Switch off the supply in both supplying lines outside the STS. Switches for both sources may be placed in some distance to the STS depending on the topology of the rest of the power system.
2. Check the absence of the voltage in two input lines with a proper voltmeter.
3. Unscrew 4 screws from the STS Board (figure 3), disconnect the Control Panel (ribbon cable inside STS Board) and take out the front cover plate of the STS Board.
4. Firmly connect three wires coming from the first supplying device (PRIMARY SOURCE) into the PRIMARY SOURCE terminal and one of the PE terminals placed on the STS Board.
5. Firmly connect three wires coming from the second supplying device (SECONDARY SOURCE) into the SECONDARY SOURCE terminal and one of the PE terminals placed on the STS Board.
6. Firmly connect wires going to the load (OUTPUT) into the STS OUTPUT terminal and one of the PE terminals placed on the STS Board.
7. Check connection of three external lines. Especially the output line going to the load should be connected to the right terminal in the STS.
8. Reinstall the cover of the STS Board and fasten it with screws. Remember to connect the ribbon cable inside the STS Board.



3.6 Starting up

3.6.1 Starting up with Switch Board

1. Make sure that all necessary connections described in chapter 3.5.1 have been made.
2. Make sure that the Integrated Switch placed on the Switch Board is turned into Normal position.
3. Starting up is performed automatically after switching one of the supplying sources on. That source will be “connected” to the load.

3.6.2 Starting up without Switch Board

1. Make sure that all necessary connections described in chapter 3.5.2 have been made. The device is ready to operate now.
2. Starting up is performed automatically after switching one of supplying sources on. That source will be “connected” to the load.



4 - Operation

The STS operates in one of the following three modes:

Preferred source mode – the selected preferred source supplies the load. The load is transferred to the other source if the voltage of the preferred source is outside acceptable rang.

Automatic retransferring mode – After a transfer triggered by disturbances in the preferred source, the load is transferred again to the preferred source with a minimum delay of 6 seconds if the preferred source is healthy again.

Manual mode – connections are set manually (not automatically).

4.1 Operation mode settings

Three buttons on the control panel determine the current operation mode: OPERATION, RETRANSFER and PREFERRED SOURCE.

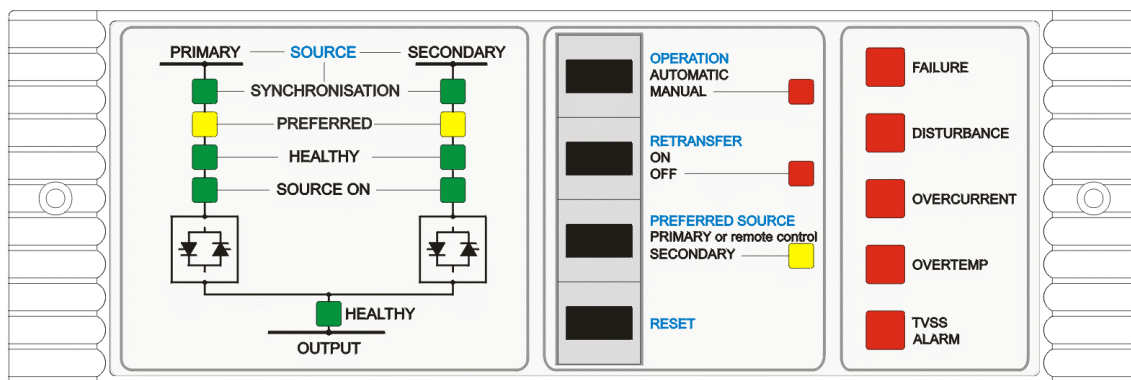

Figure 6. Control panel

4.1.1 Preferred source selection

Button designation	Position	Operation
PREFERRED SOURCE	PRIMARY – button is released	PRIMARY SOURCE or REMOTE CONTROL selected. *NOTE
	SECONDARY – button is pushed	SECONDARY SOURCE selected. SECONDARY BUTTON LED is on.

	<p>*NOTE</p> <p>If remote control signal is connected, its selection is valid. Preferred source may be selected by remote signal when PREFERRED SOURCE switch is set into “PRIMARY” position. If MANUAL mode is on, remote control is not active.</p>
--	--



4.1.2 Automatic retransferring

Button designation	Position	Operation
RETRANSFER	ON – button is pushed	Retransfer operates
	OFF – button is released	Retransfer does not operate. RETRANSFER OFF LED is on.

4.1.3 Manual operation

Button designation	Position designation	Operation
OPERATION	MANUAL – button is released	Manual operation is active. OPERATION MANUAL is on. MANUAL LED is on. *NOTE
	AUTOMATIC – button is pushed	Automatic operation is active

	<p>*NOTE</p> <p>Remote control is blocked when manual mode is on. If MANUAL mode of operation is selected, the active source may be changed even if the second one is not operational.</p>
---	---

4.1.4 Reset button

The reset button allows states of the alarms and LEDs which are memorized to be reset to default states.



4.2 Manual bypass operation with Switch Board

4.2.1 Bypassing load to primary source

**NOTE**

In case of STS failure, switch to bypass of active source

Changing operation mode from normal STS operation into primary bypass is performed by turning the Integrated Switch placed on the Switch Board in counterclockwise direction:

1. Set the Integrated Switch into “1 PRIMARY BYPASS” position.
2. Set the Integrated Switch into “2 PRIMARY BYPASS STS ISOLATED” position.

Primary bypass is now on and the Static Transfer Switch is isolated from the mains.

4.2.2 Return from primary bypass mode to STS operation

Changing the operation mode from primary bypass into normal STS operation is performed by turning the Integrated Switch placed on the Switch Board in clockwise direction:

1. Make sure that all connections between Switch Board and STS Board have been made correctly and that both cover plates are fastened properly.
2. Set the Integrated Switch into “1 PRIMARY BYPASS” position.
3. Set OPERATION button into “AUTOMATIC” position (button is pushed).
4. Set PREFERRED button into “PRIMARY” position.
5. Check if the LEDs on the Control Panel indicate the primary source is preferred, healthy and currently supplying the load.
6. Set the Integrated Switch into “NORMAL” position.

Normal STS operation mode is now switched on.



4.2.3 Bypassing load to secondary source

**NOTE**

In case of STS failure, switch to bypass of active source

Changing operation mode from normal STS operation into secondary bypass is performed by turning the Integrated Switch placed on the Switch Board in clockwise direction:

1. Set the Integrated Switch into “1 SECONDARY BYPASS” position
2. Set the Integrated Switch into “2 SECONDARY BYPASS STS ISOLATED” position

Secondary bypass is on and the Static Transfer Switch is isolated from the mains.

4.2.4 Return from secondary bypass mode to STS operation

Changing the operation mode from secondary bypass into normal STS operation is performed by turning the Integrated Switch placed on the Switch Board in counterclockwise direction:

1. Make sure that all connections between Switch Board and STS Board have been made correctly and that both cover plates are fastened properly.
2. Set the Integrated Switch into “1 SECONDARY BYPASS” position.
3. Set OPERATION button into “AUTOMATIC” position (button is pushed).
4. Set PREFERRED button into “SECONDARY” position.
5. Check if the LEDs on the Control Panel indicate that the secondary source is preferred, healthy and currently supplying the load.
6. Set the Integrated Switch into “NORMAL” position.

Normal STS operation mode is switched on now.



4.3 Service

The SCR Board may be taken out without interruption of the power supplied to the load only if the Integrated Switch has been previously set into either “2 PRIMARY BYPASS STS ISOLATED” or “2 SECONDARY BYPASS STS ISOLATED” position.

4.3.1 STS operation test

1. Make sure that both sources are healthy (their LEDs are on) and that both sources are synchronized.
2. Set the secondary source as preferred, using the PREFERRED button.
3. The STS transfers the load to the secondary source within 8 seconds. You can check it with an oscilloscope.
4. Set the primary source as preferred using the PREFERRED button.
5. The STS transfers the load to the primary source within 8 seconds. You can check it with an oscilloscope.

**NOTE**

The next step can cause loss of output voltage if the SECONDARY SOURCE or the STS is out of order.

6. Set the Integrated Switch into “1 SECONDARY BYPASS” position.
7. The STS immediately transfers the load to the secondary line. You can check the output transfer time locking output voltage waveform during transfer with an oscilloscope.
8. Set the Integrated Switch into “0 NORMAL” position.
9. The STS transfers the load to preferred primary line within 8 seconds. You can check it with an oscilloscope.
10. Set secondary line as preferred one using PREFERRED button

**NOTE**

The next step can cause loss of output voltage if the PRIMARY SOURCE or the STS is out of order.

11. Set the Integrated Switch into “1 PRIMARY BYPASS” position.
12. The STS immediately transfers the load to the primary line. You can check the output transfer time locking output voltage waveform during transfer with an oscilloscope.
13. Set the Integrated Switch into “0 NORMAL” position.
14. The STS transfers load to preferred secondary line within 8 seconds. You can check it with an oscilloscope.



4.3.2 Trouble shooting

FAILURE LED is ON	<p>A. Check if OVERCURRENT LED is off</p> <p>B. Check if OVERTEMP LED is off</p> <p>C. Press RESET button to remove memorised alarm</p>
DISTURBANCE LED is ON	<p>A. Check if PRIMARY LINE HEALTHY LED is ON</p> <p>B. Check if SECONDARY LINE HEALTHY LED is ON</p> <p>C. Check if SYNCHRONISATION LEDs are ON</p> <p>D. Check if RETRANSFER OFF LED is OFF</p> <p>E. Check if MANUAL LED is OFF</p>
OVERCURRENT LED is ON	<p>A. Check out with clamp meter if the output current of STS is correct (notice crest factor of output current)</p> <p>B. Switch off some load</p>
OVERTEMP LED is ON	<p>A. Check if air ventilation in the cabinet is sufficient</p> <p>B. Check with clamp meter if the output current of STS is correct (notice crest factor of output current). After restoring right condition (nominal load), heatsink temperature drops down below sensor deactivation level (hysteresis). It takes about 1 hour time. During that time OVERTEMP LED is on.</p>
TVSS ALARM LED is ON	Not used
RETRANSFER OFF LED is ON	Check position of RETRANSFER button – turn it into ON position (button is pushed)
MANUAL LED is ON	Check position of OPERATION button – turn it into AUTOMATIC position (button is pushed)
SYNCHRONISATION LEDs are OFF	Check phase order in both inputs X01 and X02



4.3.3 Service exchange of SCR Board with primary bypass

The following procedure allows uninterruptible exchange of SCR Board with primary bypass connected.

1. Bypass load to primary source (chapter 4.2.1).
2. Make sure that the Integrated Switch is in “2 PRIMARY BYPASS STS ISOLATED” position.
3. Open front panel of STS Board.
4. Disconnect Control Panel (ribbon cable inside of STS Board).
5. Check absence of voltages on PRIMARY SOURCE and SECONDARY SOURCE terminals of STS Board with proper voltmeter.
6. Disconnect connections between boards: PRIMARY SOURCE, SECONDARY SOURCE, STS OUTPUT, RELAY COMMUNICATION TERMINAL BLOCK and finally grounding connection (PE).
7. Take out the SCR Board.
8. Put in and screw in spare SCR Board (Advisably spare redundant board should be stored for servicing).
9. Make necessary connections between upper and lower boards: as first grounding connection (PE) and then PRIMARY SOURCE, SECONDARY SOURCE, STS OUTPUT and RELAY COMMUNICATION TERMINAL BLOCK.
10. Connect Control Panel to STS Board (ribbon cable).
11. Close front panel of STS Board.
12. Proceed with section 4.2.2: “return from primary bypass” procedure.

4.3.4 Service exchange of SCR Board with secondary bypass

The following procedure allows uninterruptible exchange of SCR Board with secondary bypass connected.

1. Bypass load to secondary source (chapter 4.2.3).
2. Make sure that the Integrated Switch is in “2 SECONDARY BYPASS STS ISOLATED” position.
3. Open front panel of STS Board.
4. Disconnect Control Panel (ribbon cable inside of STS Board).
5. Check absence of voltages on PRIMARY SOURCE and SECONDARY SOURCE terminals of STS Board with proper voltmeter.
6. Disconnect connections between boards: PRIMARY SOURCE, SECONDARY SOURCE, STS OUTPUT, RELAY COMMUNICATION TERMINAL BLOCK and finally grounding connection (PE).
7. Take SCR Board out.
8. Put in and screw in spare SCR Board (Advisably spare redundant board should be stored for servicing).
9. Make necessary connections between upper and lower boards: as first grounding connection (PE) and then PRIMARY SOURCE, SECONDARY SOURCE, STS OUTPUT and RELAY COMMUNICATION TERMINAL BLOCK.
10. Connect Control Panel to STS Board (ribbon cable).
11. Close front panel of STS Board.
12. Proceed with section 4.2.4: “return from secondary bypass” procedure.



4.4 Parameters settings (dipswitches)

	NOTE
DIP switch manipulation is allowed with SCR Board disconnected.	

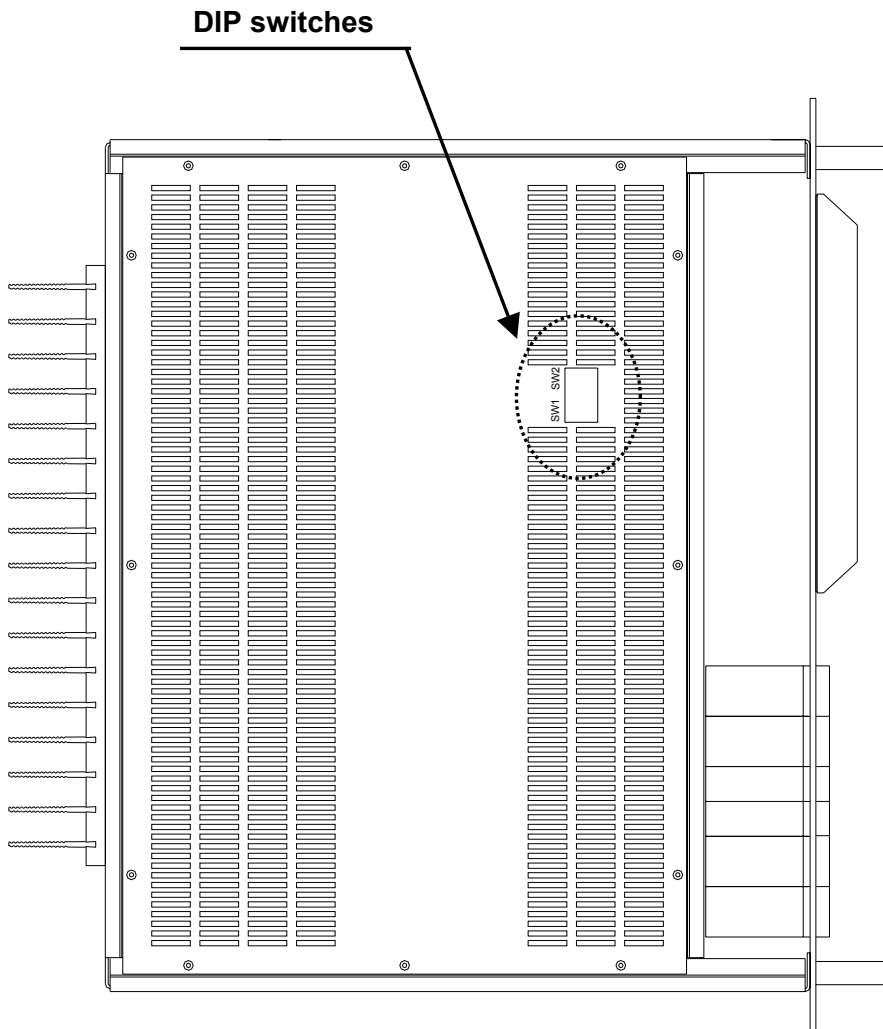
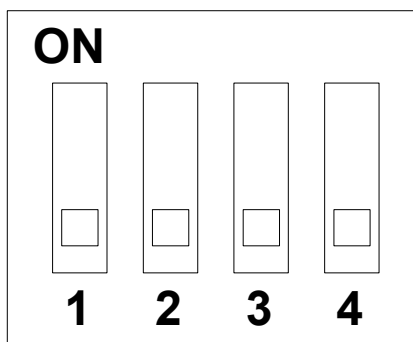

Figure 7. Access to DIP switches – inside STS Board top view



Designation on the enclosure	Function	Designation				Value
		1	2	3	4	
SW1	Undervoltage level for PRIMARY LINE	OFF	OFF	X	X	forbidden
		ON	OFF	X	X	-8%
		ON	ON	X	X	-12%
		OFF	ON	X	X	-16%
	Overvoltage level for PRIMARY LINE	X	X	OFF	OFF	forbidden
		X	X	ON	OFF	+8%
		X	X	ON	ON	+12%
		X	X	OFF	ON	+16%
SW2	Undervoltage level for SECONDARY LINE	OFF	OFF	X	X	forbidden
		ON	OFF	X	X	-8%
		ON	ON	X	X	-12%
		OFF	ON	X	X	-16%
	Overvoltage level for SECONDARY LINE	X	X	OFF	OFF	forbidden
		X	X	ON	OFF	+8%
		X	X	ON	ON	+12%
		X	X	OFF	ON	+16%

X – does not influence the parameter value for the specific function



4.5 Default DIP switch settings

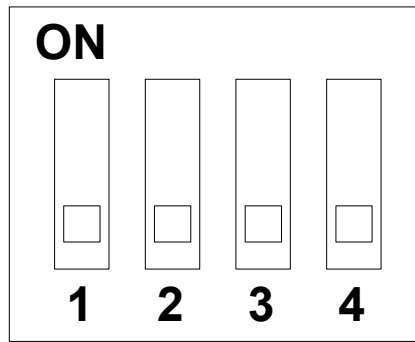

Designation on the enclosure	Function	Designation				Value
		1	2	3	4	
SW1	Undervoltage level for PRIMARY LINE	ON	OFF	ON	OFF	-8%
	Overvoltage level for PRIMARY LINE					+8%
SW2	Undervoltage level for SECONDARY LINE	ON	OFF	ON	OFF	-8%
	Overvoltage level for SECONDARY LINE					+8%



4.6 Terminals

4.6.1 Relay communication terminal block

Inputs to and outputs from the STS for controlling or monitoring functions are accessed through the RELAY COMMUNICATION TERMINAL BLOCK. Access to that terminal is after removal of front enclosure plate.

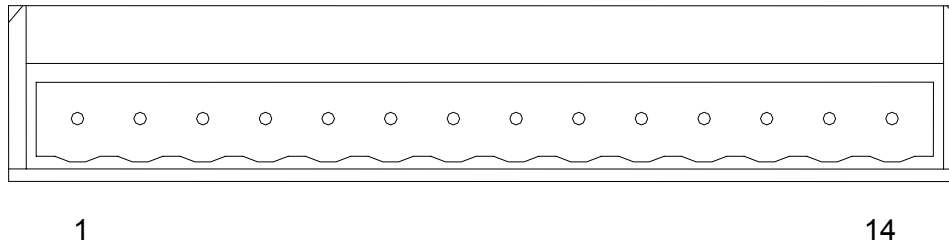

Figure 8. Relay communication terminal port view

			Meaning
1	COMM	Output	FAILURE ALARM ^{*2)} Alarm is set if there is electrical connection between "common" and "NO" terminal.
2	NO		
3	NC		
4	COMM	Output	DISTURBANCE ALARM ^{*1)} Alarm is set if there is electrical connection between "common" and "NO" terminal.
5	NO		
6	NC		
7	COMM	Output	PRIMARY LINE ON Primary line was selected if there is electrical connection between "common" and "NC" terminal.
8	NO		
9	NC		
10	COMM	Output	SECONDARY LINE ON Secondary line was selected if there is electrical connection between "common" and "NC" terminal.
11	NO		
12	NC		
13		Input	REMOTE CONTROL If closed secondary source is selected. Otherwise primary source is selected. This selection is valid if PREFERRED LINE switch is set in "PRIMARY or remote control" position.
14			

*1) DISTURBANCE ALARM appears if at least one of the following events takes place:

- Overvoltage in at least one of input lines
- Undervoltage in at least one of input lines
- Input sources unsynchronised
- Retransfer was blocked
- Internal supply failure
- Manual mode of operation was chosen

*2) FAILURE ALARM appears if at least one of the following events takes place:

- Overcurrent
- Overtemperature
- Internal STS failure

4.6.2 High current terminal

Terminal designation	Designation	Wire cross section (max)
X01, X02, X03	L, N, PE	35 mm ²



4.7 Fuse selection

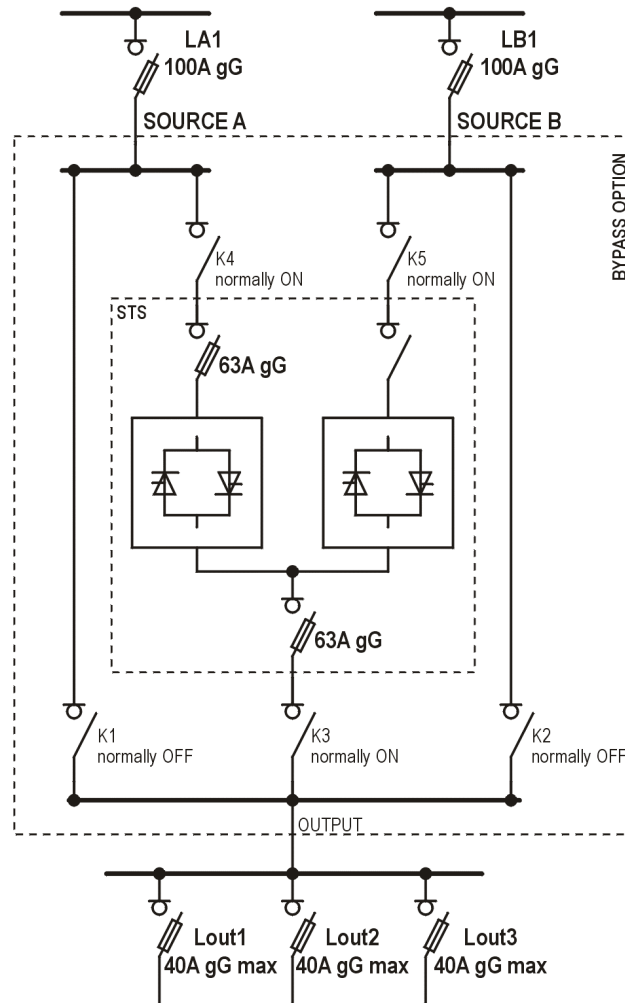

Figure 9. Overcurrent protection for supply and load lines of the STS



For selectivity of fuse operation, fuse sizes should be selected as in the tables below

STS-230-25		
Fuses of line A and B (minimum value)	STS fuses	Fuses of load lines (maximum value)
40A gG	25A gG	16A gG
25A gG	16A gG	10A gG

STS-230-40		
Fuses of line A and B (minimum value)	STS fuses	Fuses of load lines (maximum value)
63A gG	40A gG	25A gG
40A gG	25A gG	16A gG
25A gG	16A gG	10A gG

STS-230-63		
Fuses of line A and B (minimum value)	STS fuses	Fuses of load lines (maximum value)
100A gG	63A gG	40A gG
63A gG	40A gG	25A gG
40A gG	25A gG	16A gG

	<p>WARNING</p> <p>Maximum size for fuse LB1 is 125A gG</p>
--	---



5 - Specifications

5.1 Technical data

Input lines parameters (supply)		
Rated input voltage	230 V RMS phase to neutral	TN-C, TN-S
Acceptable changes of input voltages	-25% ÷ +20%	
Frequency	50 Hz	
Acceptable changes of frequency	-9% ÷ +6%	
Voltage surge withstand	<1,5kV	Iimp 7kA 8/20us
Voltage insulation	AC 2kV 60s	
Efficiency	>99%	cos(φ) > 0,8
Output line parameters		
Rated output current	STS-230-63	63 A RMS
	STS-230-40	40 A RMS
	STS-230-25	25 A RMS
Maximum crest factor	3,5	
Power factor cos(φ)	0,5-1	lag, lead
Voltage surge withstand	<1,5kV	Iimp 7kA 8/20us
Acceptable overload	125%	t=1h
	400%	t=5s
	800%	t=0,4s
	1000%	t=0,2s
	1500%	t=20ms
Short circuit withstand for thyristors (130°C)	3200A/20ms	
I ² t value for thyristors (130°C)	51200A ² s	
Breaking ability for fuses	50kA	



Operational parameter		
Preferred source selection	PRIMARY SOURCE or SECONDARY SOURCE	With retransfer or without retransfer after disturbance disappearing
Remote preferred source selection	PRIMARY SOURCE or SECONDARY SOURCE	Remote relay selection for preferred source
Overvoltage level setting	+ 8% + 12% + 16%	Transfer is performed when voltage value crosses the level. Programmed by DIP switch selection
Undervoltage level setting	- 8% - 12% - 16%	Transfer is performed when voltage value crosses the level. Programmed by DIP switch selection
Phase delay limit for synchronized sources	$\pm 16^\circ$	
Transfer blocked after output current limit exceeding	3 In	If instantaneous current value is larger than the level, transfer is not performed
Transfer delay after manual triggering with both sources synchronized	<0,2ms	
Transfer delay in automatic mode with both sources synchronized	<6ms	
Transfer delay in manual or automatic mode without synchronization	<16ms	10 ms delay added to avoid short circuit of unsynchronized sources
Retransfer to preferred line delay with both sources operational	6s	



Alarm signals		
Failure alarm	relay	FAILURE ALARM appears if at least one of the following events takes place: <ul style="list-style-type: none"> • Overcurrent • Overtemperature • Internal STS failure
Disturbance alarm	relay	DISTURBANCE ALARM appears if at least one of the following events takes place: <ul style="list-style-type: none"> • Overvoltage in at least one of input lines • Undervoltage in at least one of input lines • Input sources not synchronized • Retransfer was blocked • Internal supply failure • Manual mode of operation was chosen
PRIMARY SOURCE ON	relay	Indicating if primary source is active
SECONDARY SOURCE ON	relay	Indicating if secondary source is active
Alarm connectors parameters		
Maximum operational voltage	300V= or 250V~	
Maximum current	4A for 220V~	
	0,3A for 220V=	
Operation conditions		
Ambient temperature	0÷40°C	
Storage temperature	0÷40°C	
Humidity	max 95% without condensation	
Maximum altitude.	1000m	
Cooling	Natural	
Interference level	Level B	EN55022, EN60555-2,-3
Enclosure		
Protection	IP00	
Dimensions	483 x 458 x 312	

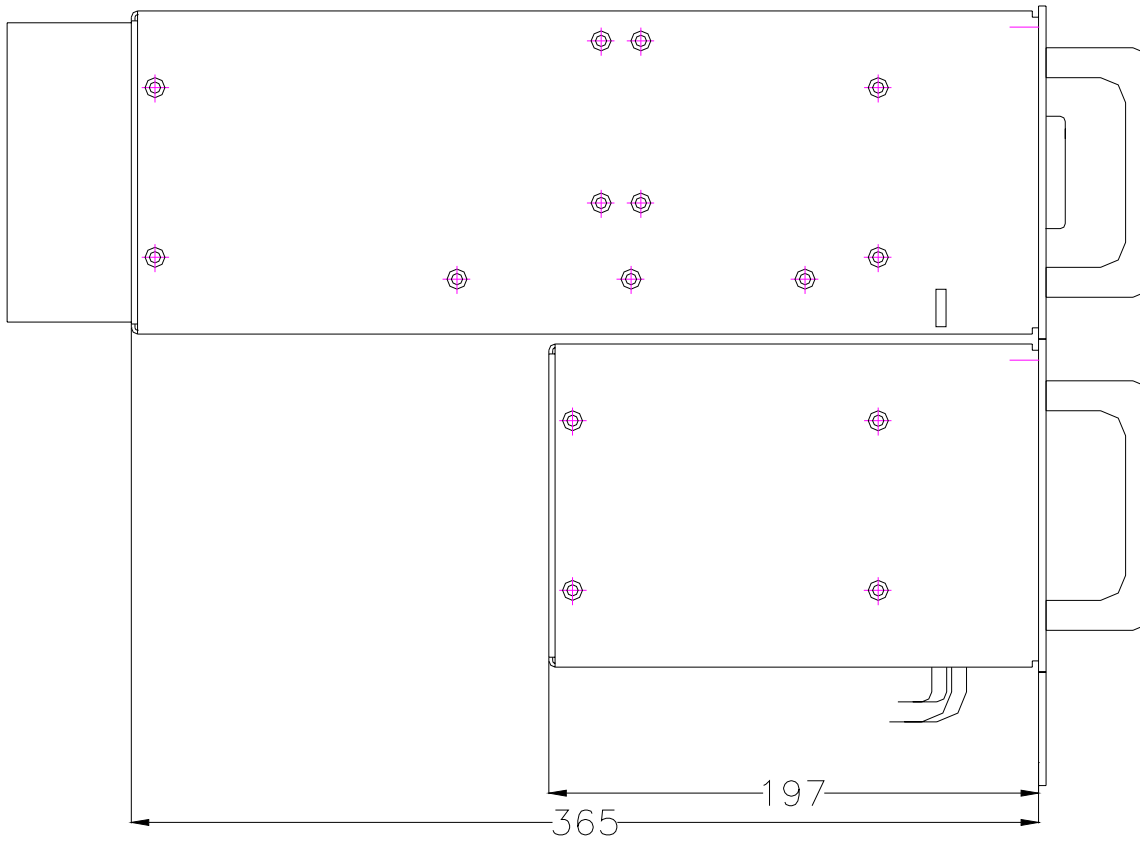

Figure 11. Side view of STS

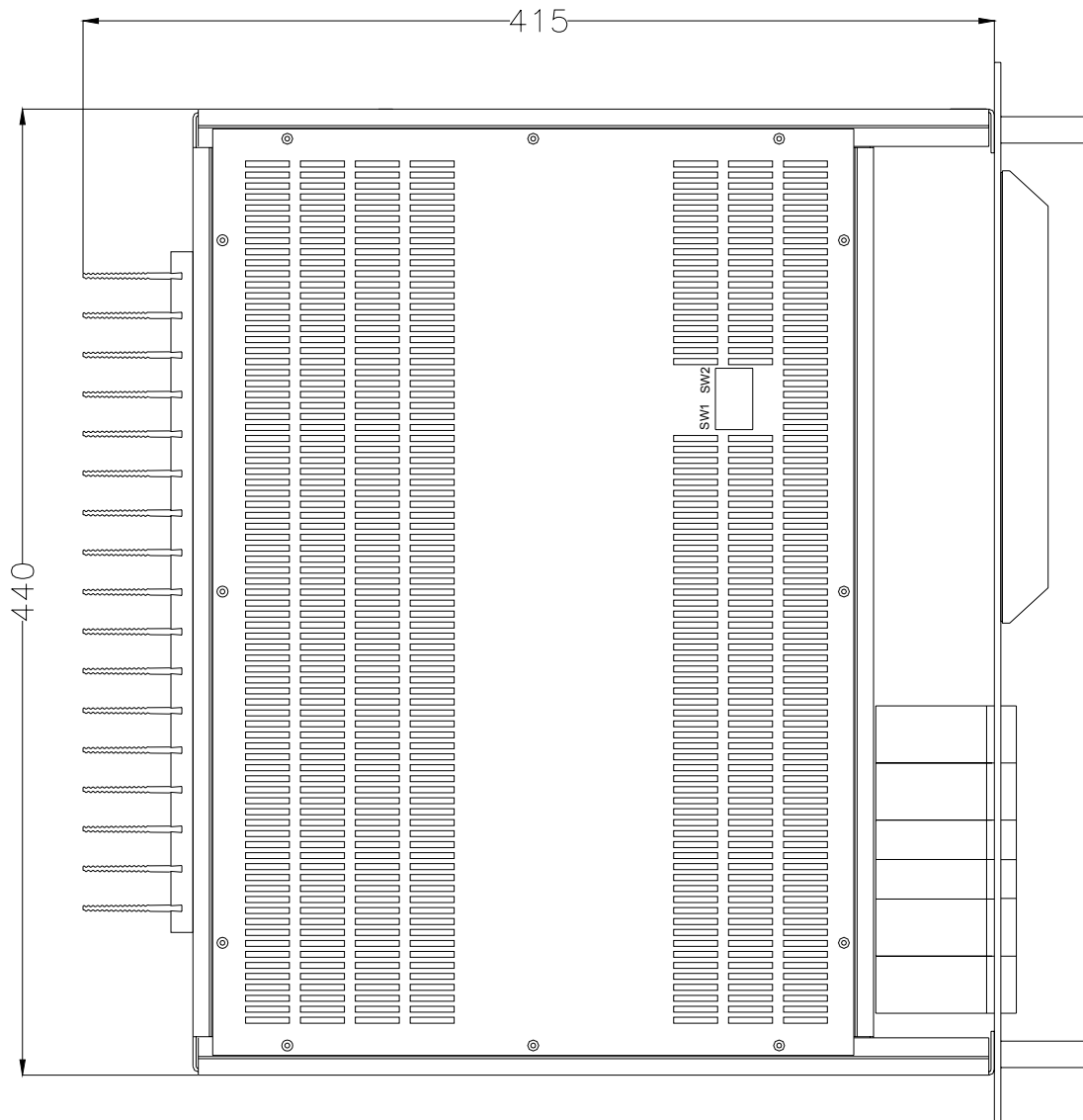

Figure 12. Top view of STS